

Les EFFECTEURS

1. Définition

Un effecteur est un composant qui agit sur la matière d'œuvre pour obtenir un valeur ajoutée.

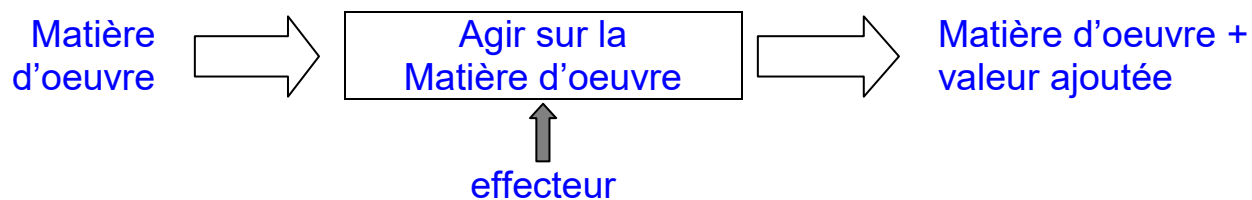

Les différentes familles d'effecteur sont :

2. Les effecteurs qui déplacent la matière d'œuvre

Convoyeur

à rouleaux



A bande



A palettes

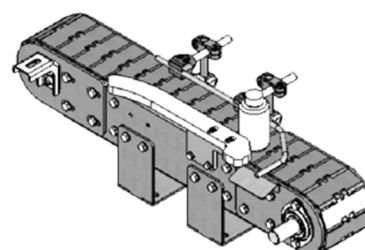

Chariots

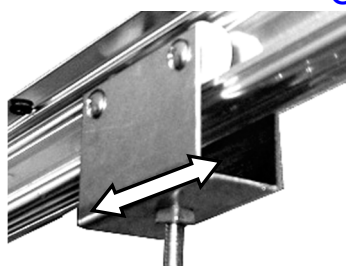

Transférer la MO d'un poste à un autre

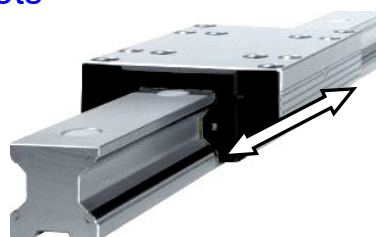

plateaux tournants

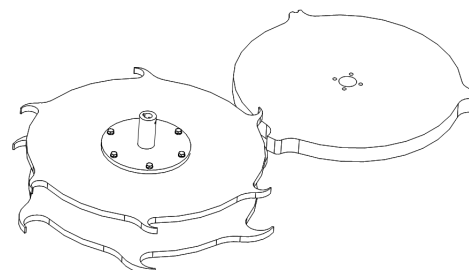
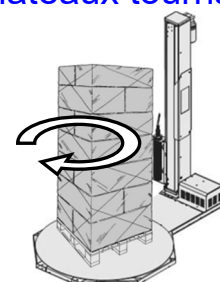

Transfert du dégroupoir

3. Les effecteurs qui saisissent la matière d'œuvre

Pincés

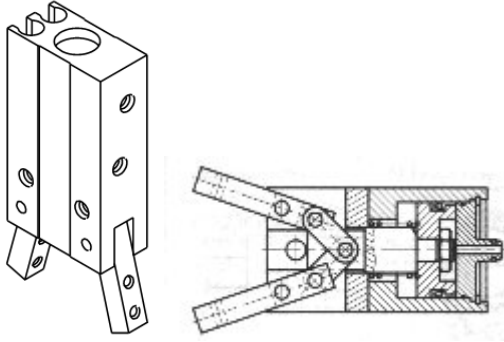

ventouse

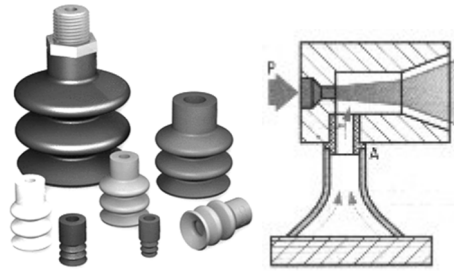

Symbole

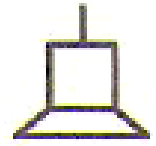

Manutention facile pour piéces non poreuses (verre, plastique)

4. Les effecteurs qui usinent la matière d'œuvre

Foréts



scie

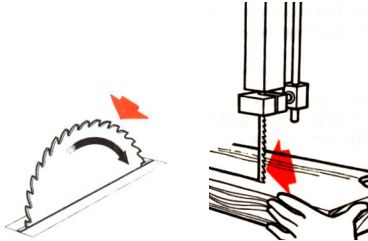

Couteaux

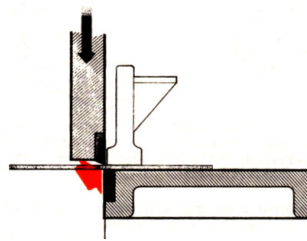

fraise



5. Les effecteurs qui forment la matière d'œuvre

Outil abrasif

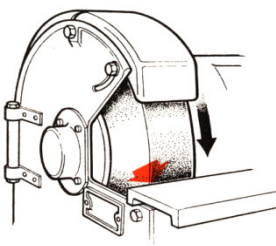

Outil de pliage

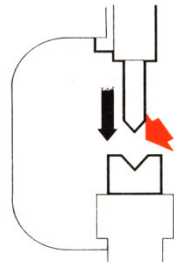

hélice

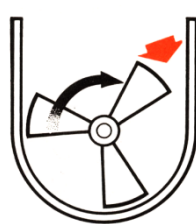

Brosses

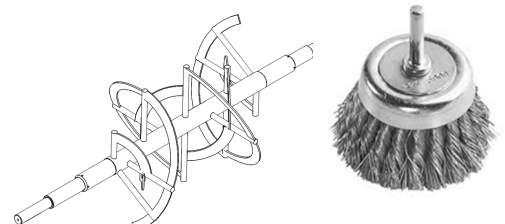

6. Les effecteurs qui positionnent la matière d'œuvre

Vis sans fin

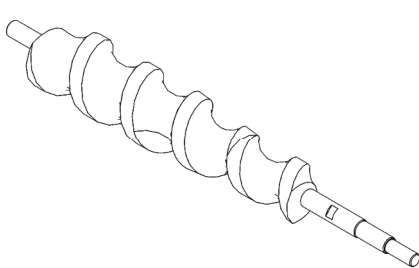

Vis du dégroupéur

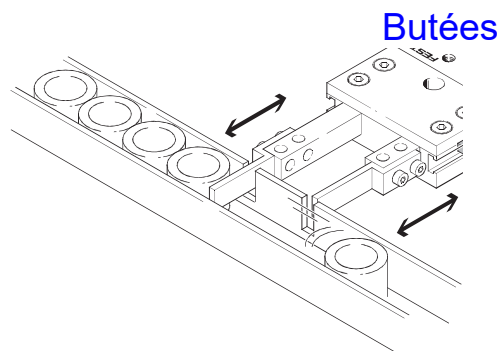

Butées

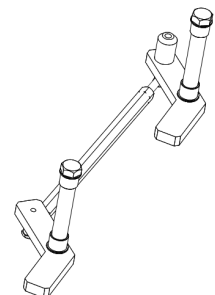

Taquets de l'empileur